

COMPLETE THIS FORM TO INITIATE SUPPLIER SCOUTING

MEPNN Supplier Scouting Opportunity Synopsis

*The submitting organization (ex. MEP Center, requesting company, federal/state agency) agrees to notify NIST MEP of the status of actions taken as a result of this scouting instance within 30 days after receiving a results report. Notification should be via email to scouting@nist.gov, indicating the following:

- Contact with matches identified in report complete and supply contract awarded, process complete
- Contact with matches identified in report complete and no supply contract awarded, process complete
- Contact with matches identified in report complete and supply negotiations underway, process in progress
- Contact with matches identified in report underway; supply negotiations not yet begun; process in progress
- Contact with matches identified in report not yet begun, process in progress
- Contact with matches identified in report will not occur within the next 6-months, process complete

_____ days
Opportunities will be posted for 30 days unless specified

Item to be Scouted

Please describe the item application/ the end use of item.* Provide the item number if applicable: (N95 Mask vs Protective Mask).

Supplier Scouting Number (NIST MEP use)

Scouting customer/product [NAICS Code](#), if known

TECHNICAL INFORMATION:	1. Supplier Information	a. Type of supplier being sought*
		<input type="checkbox"/> Manufacturer <input type="checkbox"/> Contract Manufacturer <input type="checkbox"/> Distributor <input type="checkbox"/> Other _____
	2. Summary of Technical Specifications and Performance Requirements:	b. Reason for scouting submission*
		<input type="checkbox"/> 2 nd Supplier <input type="checkbox"/> Price <input type="checkbox"/> Re-shore <input type="checkbox"/> Past supplier no longer available <input type="checkbox"/> New Product Startup <input type="checkbox"/> Other _____
		a. Describe the manufacturing processes (elaborate to provide as much detail as possible).*
		b. Provide dimensions / size / tolerances / performance specifications for the item.*
c. List required materials needed to make the product, including materials of product components.*		

2. Summary of Technical Specifications and Performance Requirements cont:	d. Are there applicable certification requirements?* <input type="checkbox"/> Yes <input type="checkbox"/> No Please explain	
	e. Are there applicable regulations?* <input type="checkbox"/> Yes <input type="checkbox"/> No Please explain	
	f. Are there any other standards, requirements, etc.?* <input type="checkbox"/> Yes <input type="checkbox"/> No Please explain	
	g. Additional Comments: Is there other information that would impact the item's performance or usefulness? Please explain.	
BUSINESS INFORMATION:	3. Volume and Pricing	3a. Estimated potential business volume (i.e., # Units Per Day, Month, Year) *:
		b. Estimated target price / unit cost information (if unavailable explain) *:
	4. Delivery Requirements:	a. When is it needed by? (Immediate, 30 Days, 6 months, etc.)*
		b. Describe packaging requirements (i.e., individually/group packaging)*
		c. Where will this item be shipped? *
	5. Additional Comments:	Is there other information you would like to include?

Photos or diagrams of the item (helpful but not required).

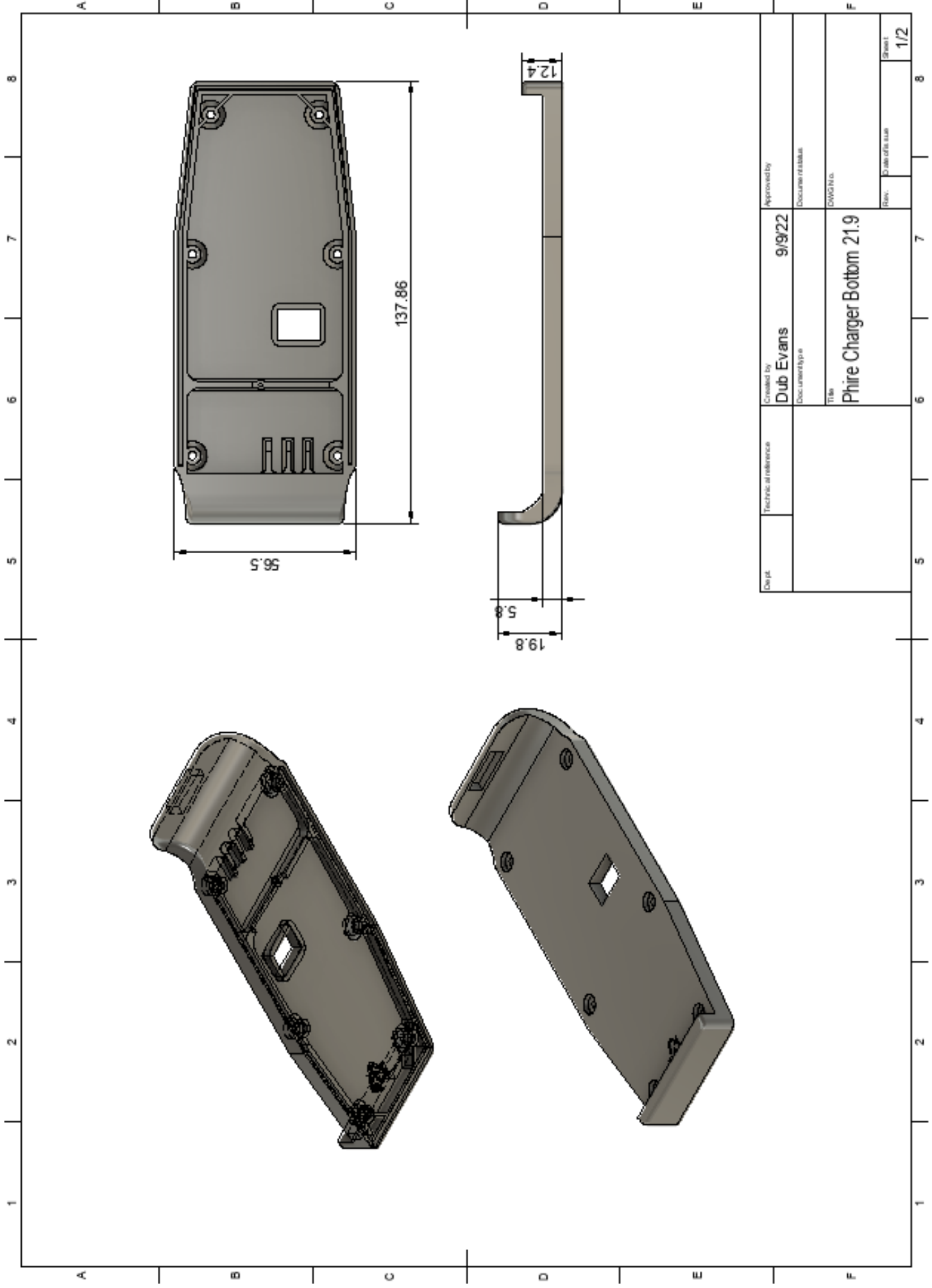

Dept.	Technical reference	Created by Dub Evans	9/9/22	Approved by	
		Document type		Document status	
		Title Phire Charger Bottom 21.9		DWG No.	
		Rev.	Date of issue	Sheet	1/2

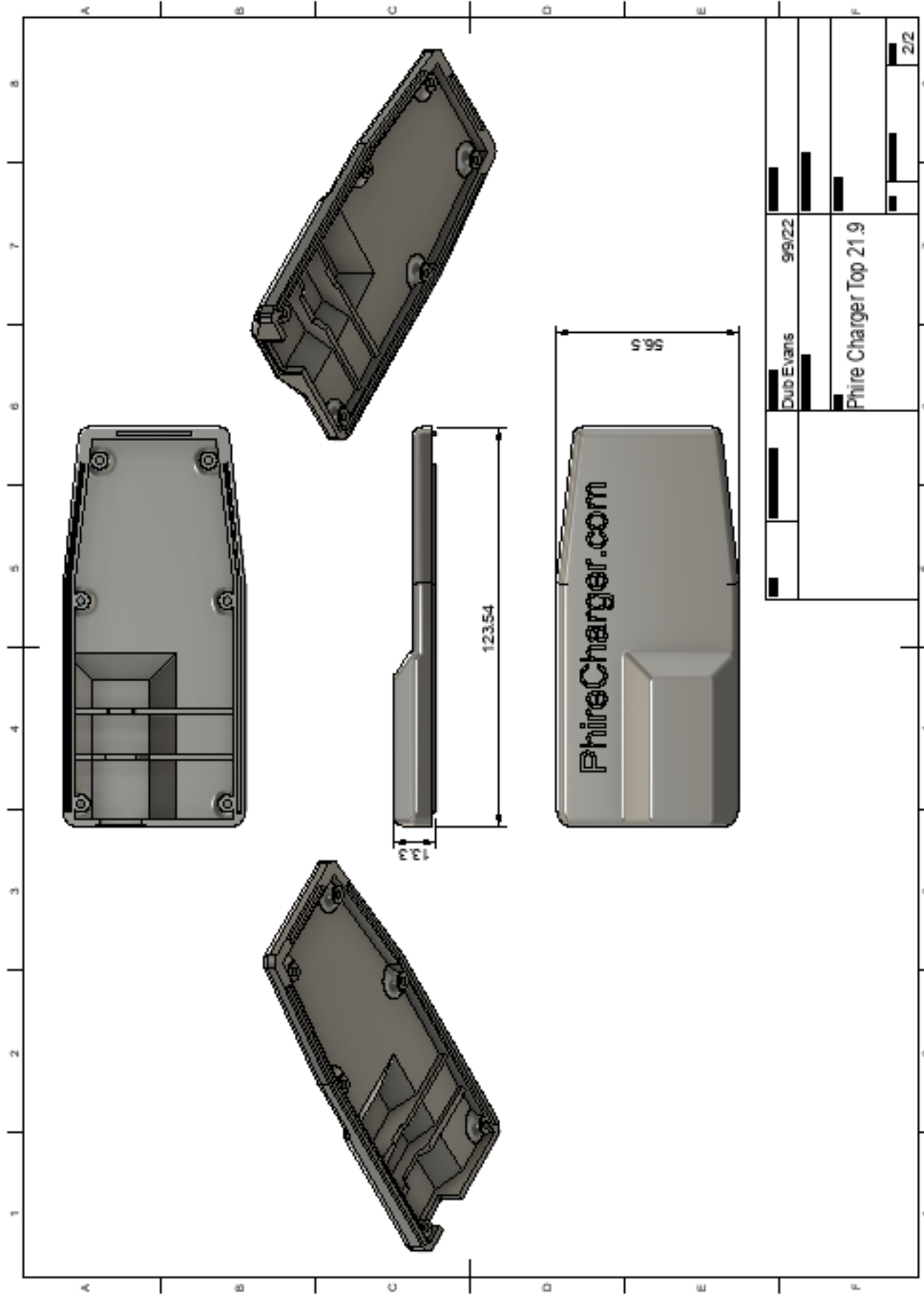

	Dub Evans	9/9/22	
	Phire Charger Top 21.9		
			2/2